

# ELECTRICAL COMPONENT LOCATION

## Tractor

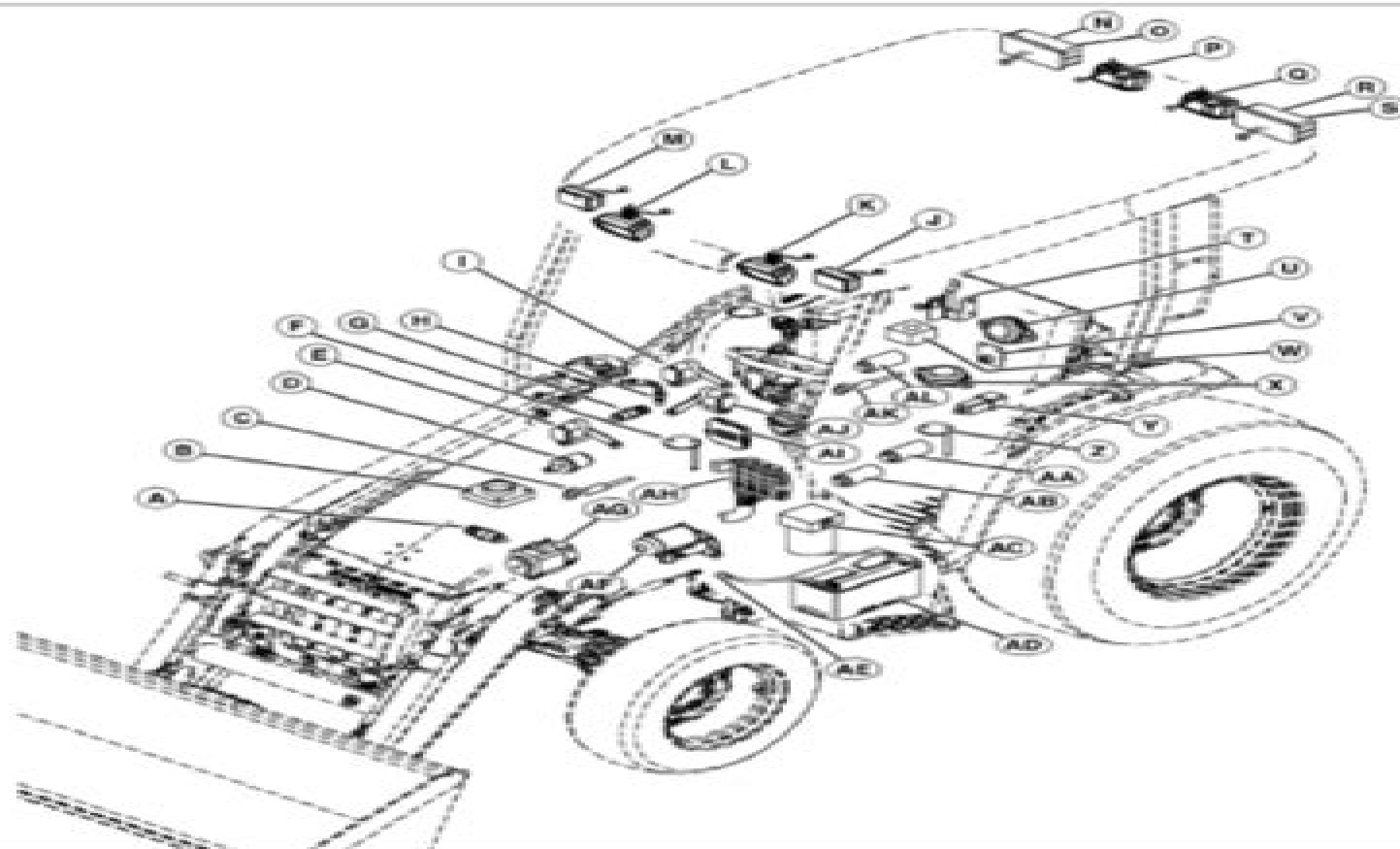

MDX14833

- A - Engine Coolant Temperature Sensor (B4)
- B - Manifold Heater (R1)
- C - Main Harness Front Ground (W2)
- D - Fuel Shutoff Solenoid (Y1)
- E - Throttle Position Potentiometer (R3)
- F - Engine Speed Sensor (B5) (at flywheel)
- G - Engine Oil Pressure Switch (B3)
- H - Air Filter Restriction Switch (B1)
- I - Reverse Pedal Potentiometer (R4)
- J - Left Front Turn Light (E8)
- K - Left Headlight (E10)
- L - Right Headlight (E9)
- M - Right Front Turn Light (E7)

- N - Right Rear Turn Light (E1)
- O - Right Tail/Brake Light (E2, E3)
- P - Right Rear Work Light (E11)
- Q - Left Rear Work Light (E12)
- R - Left Rear Turn Light (E4)
- S - Left Tail/Brake Light (E5, E6)
- T - Backhoe Switch (S6)
- U - Seat Switch (S2)
- V - Backup Alarm (H12)
- W - Backhoe Diverter Valve Solenoid (Y2)
- X - Seat Switch (S3)
- Y - Park Brake Switch (S4)
- Z - Ground Travel Speed Sensor (B6) (at MFWD gear)

# Manual 72 John Deere 110 Owners

**Michael Brown**



**Manual 72 John Deere 110 Owners:**

This is likewise one of the factors by obtaining the soft documents of this **Manual 72 John Deere 110 Owners** by online. You might not require more get older to spend to go to the ebook creation as well as search for them. In some cases, you likewise get not discover the proclamation Manual 72 John Deere 110 Owners that you are looking for. It will completely squander the time.

However below, subsequently you visit this web page, it will be as a result entirely simple to get as without difficulty as download lead Manual 72 John Deere 110 Owners

It will not undertake many get older as we accustom before. You can realize it even though enactment something else at house and even in your workplace. therefore easy! So, are you question? Just exercise just what we give below as well as evaluation **Manual 72 John Deere 110 Owners** what you next to read!

<https://staging.conocer.cide.edu/public/uploaded-files/default.aspx/ka%20service%20manual.pdf>

## **Table of Contents Manual 72 John Deere 110 Owners**

1. Understanding the eBook Manual 72 John Deere 110 Owners
  - The Rise of Digital Reading Manual 72 John Deere 110 Owners
  - Advantages of eBooks Over Traditional Books
2. Identifying Manual 72 John Deere 110 Owners
  - Exploring Different Genres
  - Considering Fiction vs. Non-Fiction
  - Determining Your Reading Goals
3. Choosing the Right eBook Platform
  - Popular eBook Platforms
  - Features to Look for in an Manual 72 John Deere 110 Owners
  - User-Friendly Interface
4. Exploring eBook Recommendations from Manual 72 John Deere 110 Owners

- Personalized Recommendations
  - Manual 72 John Deere 110 Owners User Reviews and Ratings
  - Manual 72 John Deere 110 Owners and Bestseller Lists
5. Accessing Manual 72 John Deere 110 Owners Free and Paid eBooks
    - Manual 72 John Deere 110 Owners Public Domain eBooks
    - Manual 72 John Deere 110 Owners eBook Subscription Services
    - Manual 72 John Deere 110 Owners Budget-Friendly Options
  6. Navigating Manual 72 John Deere 110 Owners eBook Formats
    - ePub, PDF, MOBI, and More
    - Manual 72 John Deere 110 Owners Compatibility with Devices
    - Manual 72 John Deere 110 Owners Enhanced eBook Features
  7. Enhancing Your Reading Experience
    - Adjustable Fonts and Text Sizes of Manual 72 John Deere 110 Owners
    - Highlighting and Note-Taking Manual 72 John Deere 110 Owners
    - Interactive Elements Manual 72 John Deere 110 Owners
  8. Staying Engaged with Manual 72 John Deere 110 Owners
    - Joining Online Reading Communities
    - Participating in Virtual Book Clubs
    - Following Authors and Publishers Manual 72 John Deere 110 Owners
  9. Balancing eBooks and Physical Books Manual 72 John Deere 110 Owners
    - Benefits of a Digital Library
    - Creating a Diverse Reading Collection Manual 72 John Deere 110 Owners
  10. Overcoming Reading Challenges
    - Dealing with Digital Eye Strain
    - Minimizing Distractions
    - Managing Screen Time
  11. Cultivating a Reading Routine Manual 72 John Deere 110 Owners
    - Setting Reading Goals Manual 72 John Deere 110 Owners
    - Carving Out Dedicated Reading Time
  12. Sourcing Reliable Information of Manual 72 John Deere 110 Owners

- Fact-Checking eBook Content of Manual 72 John Deere 110 Owners
  - Distinguishing Credible Sources
13. Promoting Lifelong Learning
- Utilizing eBooks for Skill Development
  - Exploring Educational eBooks
14. Embracing eBook Trends
- Integration of Multimedia Elements
  - Interactive and Gamified eBooks

### **Manual 72 John Deere 110 Owners Introduction**

In this digital age, the convenience of accessing information at our fingertips has become a necessity. Whether its research papers, eBooks, or user manuals, PDF files have become the preferred format for sharing and reading documents. However, the cost associated with purchasing PDF files can sometimes be a barrier for many individuals and organizations. Thankfully, there are numerous websites and platforms that allow users to download free PDF files legally. In this article, we will explore some of the best platforms to download free PDFs. One of the most popular platforms to download free PDF files is Project Gutenberg. This online library offers over 60,000 free eBooks that are in the public domain. From classic literature to historical documents, Project Gutenberg provides a wide range of PDF files that can be downloaded and enjoyed on various devices. The website is user-friendly and allows users to search for specific titles or browse through different categories. Another reliable platform for downloading Manual 72 John Deere 110 Owners free PDF files is Open Library. With its vast collection of over 1 million eBooks, Open Library has something for every reader. The website offers a seamless experience by providing options to borrow or download PDF files. Users simply need to create a free account to access this treasure trove of knowledge. Open Library also allows users to contribute by uploading and sharing their own PDF files, making it a collaborative platform for book enthusiasts. For those interested in academic resources, there are websites dedicated to providing free PDFs of research papers and scientific articles. One such website is Academia.edu, which allows researchers and scholars to share their work with a global audience. Users can download PDF files of research papers, theses, and dissertations covering a wide range of subjects. Academia.edu also provides a platform for discussions and networking within the academic community. When it comes to downloading Manual 72 John Deere 110 Owners free PDF files of magazines, brochures, and catalogs, Issuu is a popular choice. This digital publishing platform hosts a vast collection of publications from around the world. Users can search for specific titles or explore various categories and genres. Issuu offers a seamless reading experience with its user-friendly interface and allows users to download PDF files for offline reading. Apart from

dedicated platforms, search engines also play a crucial role in finding free PDF files. Google, for instance, has an advanced search feature that allows users to filter results by file type. By specifying the file type as "PDF," users can find websites that offer free PDF downloads on a specific topic. While downloading Manual 72 John Deere 110 Owners free PDF files is convenient, its important to note that copyright laws must be respected. Always ensure that the PDF files you download are legally available for free. Many authors and publishers voluntarily provide free PDF versions of their work, but its essential to be cautious and verify the authenticity of the source before downloading Manual 72 John Deere 110 Owners. In conclusion, the internet offers numerous platforms and websites that allow users to download free PDF files legally. Whether its classic literature, research papers, or magazines, there is something for everyone. The platforms mentioned in this article, such as Project Gutenberg, Open Library, Academia.edu, and Issuu, provide access to a vast collection of PDF files. However, users should always be cautious and verify the legality of the source before downloading Manual 72 John Deere 110 Owners any PDF files. With these platforms, the world of PDF downloads is just a click away.

### **FAQs About Manual 72 John Deere 110 Owners Books**

1. Where can I buy Manual 72 John Deere 110 Owners books? Bookstores: Physical bookstores like Barnes & Noble, Waterstones, and independent local stores. Online Retailers: Amazon, Book Depository, and various online bookstores offer a wide range of books in physical and digital formats.
2. What are the different book formats available? Hardcover: Sturdy and durable, usually more expensive. Paperback: Cheaper, lighter, and more portable than hardcovers. E-books: Digital books available for e-readers like Kindle or software like Apple Books, Kindle, and Google Play Books.
3. How do I choose a Manual 72 John Deere 110 Owners book to read? Genres: Consider the genre you enjoy (fiction, non-fiction, mystery, sci-fi, etc.). Recommendations: Ask friends, join book clubs, or explore online reviews and recommendations. Author: If you like a particular author, you might enjoy more of their work.
4. How do I take care of Manual 72 John Deere 110 Owners books? Storage: Keep them away from direct sunlight and in a dry environment. Handling: Avoid folding pages, use bookmarks, and handle them with clean hands. Cleaning: Gently dust the covers and pages occasionally.
5. Can I borrow books without buying them? Public Libraries: Local libraries offer a wide range of books for borrowing. Book Swaps: Community book exchanges or online platforms where people exchange books.
6. How can I track my reading progress or manage my book collection? Book Tracking Apps: Goodreads, LibraryThing,

and Book Catalogue are popular apps for tracking your reading progress and managing book collections. Spreadsheets: You can create your own spreadsheet to track books read, ratings, and other details.

7. What are Manual 72 John Deere 110 Owners audiobooks, and where can I find them? Audiobooks: Audio recordings of books, perfect for listening while commuting or multitasking. Platforms: Audible, LibriVox, and Google Play Books offer a wide selection of audiobooks.
8. How do I support authors or the book industry? Buy Books: Purchase books from authors or independent bookstores. Reviews: Leave reviews on platforms like Goodreads or Amazon. Promotion: Share your favorite books on social media or recommend them to friends.
9. Are there book clubs or reading communities I can join? Local Clubs: Check for local book clubs in libraries or community centers. Online Communities: Platforms like Goodreads have virtual book clubs and discussion groups.
10. Can I read Manual 72 John Deere 110 Owners books for free? Public Domain Books: Many classic books are available for free as they're in the public domain. Free E-books: Some websites offer free e-books legally, like Project Gutenberg or Open Library.

### **Find Manual 72 John Deere 110 Owners :**

[ka service manual](#)

**kaplan nursing question trainer 2**

[kanski clinical study guide](#)

[k7j engine 700 manual meat](#)

**karcher 390 manual**

[kaeser sm15 manual](#)

**jvc xl pm20sl user guide**

**kaplan and sadocks synopsis of psychiatry behavioral sciences**

**jvc rc-qn3 manual**

[kaplan anatomy study guide coloring](#)

[kansas city lightning](#)

[kato alternator manual](#)

[kate quelque part](#)

[kappo technique study guide](#)



*kaplan and bpp acca study text*

**Manual 72 John Deere 110 Owners :**

*democracy in action assessment answers* - Mar 23 2022

web merely said the democracy in action assessment answers is universally compatible with any devices to read controlling bureaucracies judith e gruber 1987 01 01 the author treats the classic problem of achieving democratic control over powerful bureaucracies very successfully both by treating familiar material in a new and important

democracy in action teaching resources ppt - Nov 30 2022

web civic action project democracy project a four week project which demonstrates democratic processes and ideals for 10th grade world history use with your democratic principles unit on ancient greece rome and the enlightenment can be used in any unit relating to government democracy or civics

**introducing democracy 80 questions and answers unesco** - Jan 01 2023

web this book tackles these and other questions about democracy covering six broad areas basic concepts and principles free and fair elections open and accountable government individual rights and their defence democratic or civil society the future of democracy

**united states government democracy in action 9780078747625 quizlet** - Aug 08 2023

web find step by step solutions and answers to united states government democracy in action 9780078747625 as well as thousands of textbooks so you can move forward with confidence

questions and answers european democracy action plan - Aug 28 2022

web the commission launched a public consultation which was running from 15 july to 18 september 2020 the consultation received a total of 338 responses 208 61 of which were submitted by individuals and 130 38 by public authorities ngos academia businesses associations companies and trade unions

**democracy in action assessment answers pdf data northitalia** - Apr 23 2022

web democracy in action assessment answers pisa take the test sample questions from oecd s pisa assessments cybersecurity in elections introducing democracy school family and community partnerships poverty in the philippines blessed are the organized the enduring democracy democracy in one book or less lord of the flies united

**intermediate listening democracy in action esl lounge student** - Jul 07 2023

web 1 richard cookson is a member of the governing party 2 anne is still not sure who she is going to vote for 3 there has recently been a referendum 4 richard cookson denies the information that anne saw in the campaign ad 5

**democracy in action worksheets learny kids** - Jun 25 2022

web displaying top 8 worksheets found for democracy in action some of the worksheets for this concept are discovering democracy in action discovering democracy in action democracy in action democracy in action glencoe skills work chapter 2 notes democracy chapter overview civics text united states government democracy in *united states government democracy in action quizlet* - Oct 10 2023

web our resource for united states government democracy in action includes answers to chapter exercises as well as detailed information to walk you through the process step by step with expert solutions for thousands of practice problems you can take the guesswork out of studying and move forward with confidence

in a democratic government a citizen has the right and the - May 25 2022

web nov 4 2023 democracy guarantees that decision making will be based on norms and norms therefore a citizen who wants to know if a decision has been made through the appropriate procedures can find this you have the right and means to evaluate the decision making process complete solution everyone has the right to access government

**chapter 1 people and government henry county schools** - Apr 04 2023

web the democracy in action video program independence hall shows the unique role of independence hall in american history as you view the video program try to identify some of the people involved in framing the united states government hands on activity

*united states government democracy action quizlet* - Mar 03 2023

web learn united states government democracy action with free interactive flashcards choose from 500 different sets of united states government democracy action flashcards on quizlet

*democracy in action class 7 social studies civics youtube* - Feb 19 2022

web democracyinaction democracy class7socialscience class7socialsciencercert copyright 2020 orchids elearni

**unit 1 democracy in action ccea** - Jun 06 2023

web an answer that fails to refer to the source can be awarded a maximum of level 2 answers may include some of the following from source mps represent their constituents mps ask questions in parliament on behalf of their constituents from own knowledge mps suggest private members bills mps hold surgeries or clinics in their local constituencies

**free what is democracy interactive powerpoint twinkl** - Jul 27 2022

web this interactive powerpoint aims to answer the question what is democracy for second level learners it includes a quiz for an assessment opportunity

**democracy in action service learning civic engagement** - Sep 28 2022

web democracy in action is a community engagement practice through which csusm faculty and students partner with a local city government to conduct research gathering qualitative and quantitative data to benefit city projects that are back logged

or need additional attention faculty and students work closely with city officials to hone their

**lesson what is a strong democracy elections** - Oct 30 2022

web democracy and briefly discuss how each one is necessary for a democracy to be healthy and strong explain to students that all citizens have a responsibility to keep democracy alive and well consider making a list together of words or phrases associated with a strong democracy and then a list of words and phrases associated with a weak

*united states government democracy in action mcgraw hill* - May 05 2023

web united states government democracy in action beyond the textbook state resources landmark supreme court cases nations of the world atlas current events and interactive time line virginia people and documents time line virginia today textbook resources studentworks plus online

tool democracy assessments civicus global alliance - Feb 02 2023

web 4 making the democracy assessment public the final goal of a democracy assessment is to give a country s society at large a thorough analysis of the strengths and weaknesses of its democratic arrangements so that the citizens become aware and take appropriate actions therefore the final report has to be widely

united states government democracy in action quizlet - Sep 09 2023

web find step by step solutions and answers to exercise 4 from united states government democracy in action 9780078799822 as well as thousands of textbooks so you can move forward with confidence

**electrical engineering semester 7 question papers sppu** - Dec 27 2021

web download savitribai phule pune university sppu question papers for electrical engineering semester 7

**electrical engineering 2nd sem previous years question papers** - Apr 30 2022

web electrical engineering 2nd sem previous years question papers download electrical engineering 2nd sem previous years question papers for assam polytechnics get assam polytechnics old question papers 2019 2020 pdf download electrical engineering 2nd sem previous years question papers for assam polytechnics

*ese 2020 mains question papers with detailed solutions ace* - Dec 07 2022

web electrical engineering question papers paper i paper ii question papers paper i paper ii questions with solutions paper i paper ii civil engineering question papers paper i paper ii questions with solutions paper i paper ii about ace ace engineering academy was established in the year 1995 with a prime motto of imparting

**2007 2022 ssc je electrical question papers pdf download** - Mar 30 2022

web mar 5 2023 the table below provides previous year question papers and sample papers with solutions for all ssc je exams in electrical engineering from 2007 to 2015 downloading ssc je previous year question papers in pdf format for electrical engineering can be helpful in cracking the ssc je exam

**electrical engineering question papers mumbai university** - Jun 13 2023

web free download of mumbai university mu electrical engineering question papers solutions study notes model answers syllabus exam timetable cgpa to percentage converter second year s e sem 3 4 third year t e sem 5

*electrical engineering 1st sem previous years question papers* - Mar 10 2023

web in this blog you will get all the previous year s question papers for electrical engineering 1st semester diploma in mechanical engineering civil engineering electrical engineering electronics computer and chemical engineering subjects ranging from 2013 to the present date

**gate electrical engineering question papers pdf download ee papers** - Jan 28 2022

web aug 16 2023 as per the gate 2024 exam pattern the question paper will contain different types of questions including multiple choice questions mcqs numerical answer type nat questions and multiple select questions msqs read more to download previous year gate electrical question paper with solution

**electrical engineering previous year semester question papers** - Jun 01 2022

web browse year wise ee 2023 ee 2022 ee 2020 ee 2019 ee 2018 ee 2017 ee 2016 ee 2015 ee 2014 ee 2013 ee 2012 ee 2011 ee 2010 ee 2009 ee 2008 ee 2007 ee 2006 ee 2005 ee 2004 ee 2003 ee 2001 ee 2000 this page was last edited on 24 april 2023 at 07 55

*electrical engineering questions and answers indiabix* - May 12 2023

web electrical engineering list of topics quantities and units voltage current and resistance ohm s law energy and power series circuits parallel circuits series parallel circuits circuit theorems and conversions branch loop and node analyses magnetism and electromagnetism alternating current and voltage capacitors inductors transformers

*pdf electrical engineering gate previous years question papers* - Apr 11 2023

web in this page gate previous years papers are collected from 2003 to 2022 till this year totally 19 years gate electrical engineering previous question papers are available to download where can i get the last 10 years gate electrical engineering question papers with solution

be3251 basic electrical and electronics engineering question papers - Feb 09 2023

web oct 3 2022 be3251 beee question paper we are providing the be3251 basic electrical and electronics engineering question papers first and are exclusively available on our website below for your examination success use our materials to score good marks in the examination best of luck

**gate electrical engineering ee 2023 question papers** - Feb 26 2022

web sep 1 2023 gate 2024 exam pattern will include the number of questions types of questions and marking scheme for all the 30 papers of gate candidates who wish to appear for gate 2024 need to familiarise themselves with the exam pattern

syllabus and marking scheme in all the papers there will be a total of 65 questions carrying 100

*electrical engineering previous paper 1 question paper* - Sep 04 2022

web nov 17 2020 david kanoma on december 18 2021 at 8 00 am send me papers for 2019 in all subjects power electrical diploma level 6 year 1 shaabe on october 20 2021 at 5 07 pm may i get electrical 1 question paper kalai on december 29 2020 at 2 58 am i need electrical engineering questions janhvi tiwari on november 26 2020 at 6 22 am

electrical engineering previous papers question paper - Aug 15 2023

web we are providing you the electrical engineer previous papers with answer key candidates who are downloading the electrical engineer previous year question papers are also suggested to download the answer key

**ies electrical engineering previous year papers kopykitab** - Oct 05 2022

web jul 4 2023 ies electrical engineering previous year papers if you are preparing for ies exam then you should practice enough question papers to boost your preparation we have provided the year wise ies ese electrical engineering question papers

ife221 past exam questions and answers eastern - Jul 14 2023

web faculty of engineering department of electrical and electronic engineering fall 2017 18 ife221 exam questions and solutions past exam questions and answers

**ph3202 physics for electrical engineering question papers 2021** - Jul 02 2022

web dec 2 2022 ph3202 pee question paper we are providing the ph3202 physics for electrical engineering question papers first and exclusively available on our website below for your examination success use our materials to score good marks in the examination best of luck regulation

electrical engineering exams practice set papers model sample papers - Nov 06 2022

web get free electrical engineering practice set papers for the preparation of electrical engineering 2024 exams the electrical engineering exams previous year solved papers are available online with the solutions and answers to improve the performance

*ssc je ee previous year papers download free question paper* - Aug 03 2022

web nov 14 2022 these papers are the precursor to your actual je ee exam and were set by the ssc officials these papers will give you an idea of all aspects of the exam its question trend difficulty level exam pattern and much more learn from best online coaching for ssc je ee ssc je ee previous year questions paper with solutions

**gate ee previous year question papers with solutions** - Jan 08 2023

web gate aspirants need to practice the questions on a regular basis for assessing the self preparations for the final gate exams here we have provided the compilation of the electrical engineering previous year question papers these question

papers allow students to work on their weak areas

*art 187 codice della strada guida in stato di alterazione psico - Apr 14 2023*

web 1 chiunque guida in stato di alterazione psico fisica dopo aver assunto sostanze stupefacenti o psicotrope è punito con l'ammenda da 1500 a 6 000 e l'arresto da sei mesi ad un anno all'accertamento del reato consegue in ogni caso la sanzione amministrativa accessoria della sospensione della patente di guida da uno a due anni

**guida in stato di alterazione psicofisica consortium forense - May 15 2023**

web dec 19 2019 la condotta tipica della contravvenzione di cui all'art 187 c d s non è quella di chi guida dopo avere assunto sostanze stupefacenti bensì quella di colui che guida in stato di alterazione psicofisica determinato da tale assunzione

**guida in stato di alterazione psico fisica l esem pdf wrbb neu - Apr 02 2022**

web as this guida in stato di alterazione psico fisica l esem it ends taking place mammal one of the favored books guida in stato di alterazione psico fisica l esem collections that we have this is why you remain in the best website to see the amazing ebook to have guida in stato di alterazione psico fisica l esem 2020 07 10 becker byron

*art 187 c d s guida in stato di alterazione psico fisica per uso - Jun 16 2023*

web guida in stato di alterazione psico fisica per uso di sostanze stupefacenti 1 chiunque guida in stato di alterazione psico fisica dopo aver assunto sostanze stupefacenti o psicotrope è punito con l'ammenda da euro 1 500 a euro 6 000 e

**guida in stato di alterazione psico fisica l esem full pdf - Jan 31 2022**

web 4 guida in stato di alterazione psico fisica l esem 2023 02 10 di contraddizioni guida in stato di ebbrezza maggioli editore la cannabis rappresenta la sostanza illegale più frequentemente utilizzata nel mondo ed è quella maggiormente abusata da parte di guidatori che riferiscono di aver guidato dopo aver fatto uso di sostanze stupefacenti dal

guida in stato di alterazione psico fisica l esem pdf book - Aug 06 2022

web may 24 2023 pronouncement guida in stato di alterazione psico fisica l esem pdf can be one of the options to accompany you similar to having other time it will not waste your time agree to me the e book will categorically publicize you new business to read just invest tiny epoch to open this on line message guida in stato di alterazione psico

guida in stato di alterazione psico fisica l esem pdf - Jul 05 2022

web guida in stato di alterazione psico fisica per uso di guida senza patente e in stato di alterazione psicofisica art 187 codice della strada guida in stato di

**guida in stato di alterazione psico fisica l esem copy - Sep 07 2022**

web guida in stato di alterazione psico fisica l esem recognizing the showing off ways to acquire this books guida in stato di alterazione psico fisica l esem is additionally useful you have remained in right site to begin getting this info get the guida in

stato di alterazione psico fisica l esem partner that we manage to pay for here and check

*guida in stato di ebbrezza e di alterazione psico fisica analisi* - Dec 10 2022

web guida in stato di ebbrezza e di alterazione psico fisica analisi dei reati è un libro di simone marani pubblicato da altalex nella collana altalex professionale acquista su ibs a 27 55

guida in stato di alterazione psico fisica l esem pdf - Jun 04 2022

web 2 guida in stato di alterazione psico fisica l esem 2020 05 04 guida in stato di alterazione psico fisica l esem 2020 05 04 sanaa deanna i reati nel codice della strada con cd rom maggioli editore il volume contiene una trattazione completa e interdisciplinare del diritto penale della circolazione stradale oltre alla disamina dei

**guida in stato di alterazione psico fisica non basta** - Jul 17 2023

web mar 31 2021 guida in stato di alterazione psico fisica non basta l accertamento dell assunzione di stupefacenti premessa la iv sezione della corte di cassazione si è occupata recentemente del reato di guida in stato di alterazione psico fisica per uso di sostanze stupefacenti ex art 187 cds stabilendo con sentenza n 3900 2021 la

**guida in stato di alterazione psico fisica l esem** - Mar 01 2022

web guida in stato di alterazione psico fisica l esem 1 guida in stato di alterazione psico fisica l esem la guida in stato di ebbrezza e sotto l effetto di stupefacenti codice della strada infortuni in itinere aspetti medico legali norma giurisprudenza e dottrina nuovo codice della strada commentato con cd rom il nuovo reato di omicidio stradale

*guida in stato di alterazione psicofisica per uso* - Sep 19 2023

web guida in stato di alterazione psicofisica per uso di sostanze stupefacenti giudici della quarta sezione penale della corte di cassazione con la sentenza n 8417 del 14 marzo 2022 hanno ritenuto che l alterazione richiesta per l integrazione del reato previsto per uso di sostanze stupefacenti esige l accertamento di

**guida in stato di alterazione psico fisica l esem wrbb neu** - Oct 08 2022

web download and install guida in stato di alterazione psico fisica l esem correspondingly simple guida in stato di alterazione psico fisica l esem 2020 08 15 hezekiah walker guida in stato di alterazione da alcol e da sostanze stupefacenti e book maggioli editore

guida in stato di alterazione psico fisica per uso di sostanze - Feb 12 2023

web feb 21 2019 cosa prevede l art 187 del codice della strada la fattispecie è disciplinata dall art 187 del codice della strada rubricato guida in stato di alterazione psico fisica per uso di sostanze stupefacenti la norma punisce con una pesante sanzione penale chiunque si ponga alla guida di un mezzo di trasporto compresa la

guida in stato di alterazione psico fisica l esem pdf - May 03 2022

web guida in stato di alterazione psico fisica l esem guida in stato di alterazione da alcol e da sostanze stupefacenti e book il

civilista il nuovo codice della strada circolazione stradale immigrazione criminalità sicurezza pubblica il nuovo reato di omicidio stradale prontuario di polizia giudiziaria guida in stato di ebbrezza e di rischia di investire un carabiniere al posto di blocco e fugge a - Mar 13 2023

web oct 20 2023 i carabinieri della sezione radiomobile della compagnia di parma hanno denunciato in stato di libertà un 23 enne reggiano per resistenza a p u e guida in stato di alterazione psico fisica l guida in stato di alterazione psico fisica per uso di sostanze - Jan 11 2023

web aug 30 2013 guida in stato di alterazione psico fisica per uso di sostanze stupefacenti quando si configura il reato di redazione 30 agosto 2013 cassazione penale sez feriale 30 agosto 2013 n 35783

**art 187 codice della strada guida in stato di alterazione psico** - Aug 18 2023

web apr 30 1992 chiunque guida in stato di alterazione psico fisica dopo aver assunto sostanze stupefacenti o psicotrope è punito con l ammenda da euro 1 500 a euro 6 000 e l arresto da sei mesi ad un anno all accertamento del reato consegue in ogni caso la sanzione amministrativa accessoria della sospensione della patente di guida da uno a

*guida in stato di alterazione psico fisica l esem 2023* - Nov 09 2022

web guida in stato di alterazione psico fisica l esem 2 downloaded from interactivearchivist archivists org on 2022 10 29 by guest mare 16 ilmattino it le destre e il proibizionismo a senso unico volerelaluna it taxi gratis in discoteca quali locali fino a quando velvet mag